

## Construction

1:

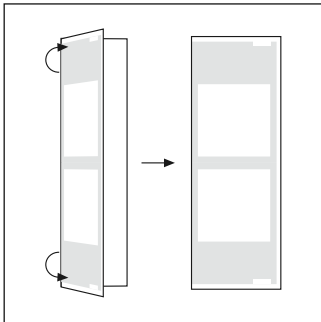

2:

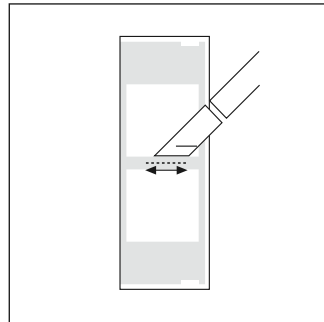

3:

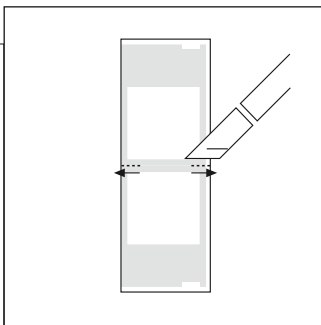

4:

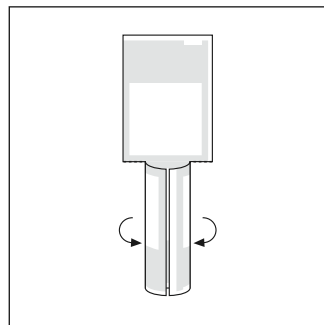

5:

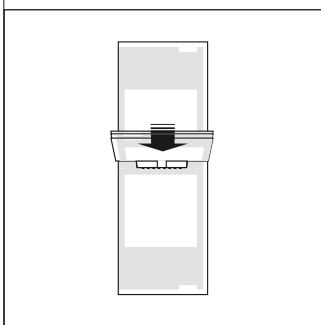

6:

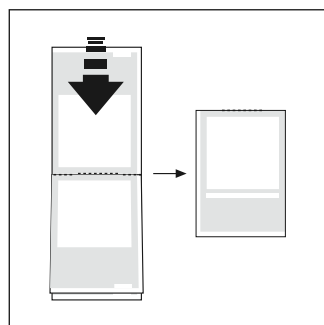

- 1: First, fold each A4 sheet in half along the vertical axis.
- 2: Using a craft knife or scalpel, cut a horizontal slot along the centre dotted line of the first A4 sheet. (pages 1/2/13/14)
- 3: Then cut along the dotted lines on all the other sheets. Make sure to cut to the very edges of the paper.
- 4: Stack the folded sheets in ascending order with the even numbers at the top. Curl the bottom half of the second A4 page (pages 3/4/23/24).
- 5: Thread the curled page through the centre slot of the first A4 page. Repeat this process with the third (pages 5/6/21/22), fourth (pages 7/8/19/20), fifth (pages 9/10/17/18), and sixth A4 sheet (pages 11/12/15/16) with the even pages in ascending order.
- 6: When all the pages have been threaded through, check the pagination. Finally, fold the booklets in half along the horizontal axis.

### Sound Diary

Date:

Place:

Large empty rectangular box for writing the sound diary entry.

Large empty rectangular box for writing the sound diary entry.

Place:

Date:

### Sound Diary

Small empty rectangular box for writing the date and place.

## SOUND SCAVENGER

### Sound Diary

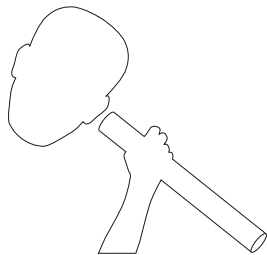

### eNotebook

.....  
Listener's Name

Large vertical rectangular box with horizontal dashed lines for notes, and a small box at the bottom for 'Sound Words'.

Sound Words

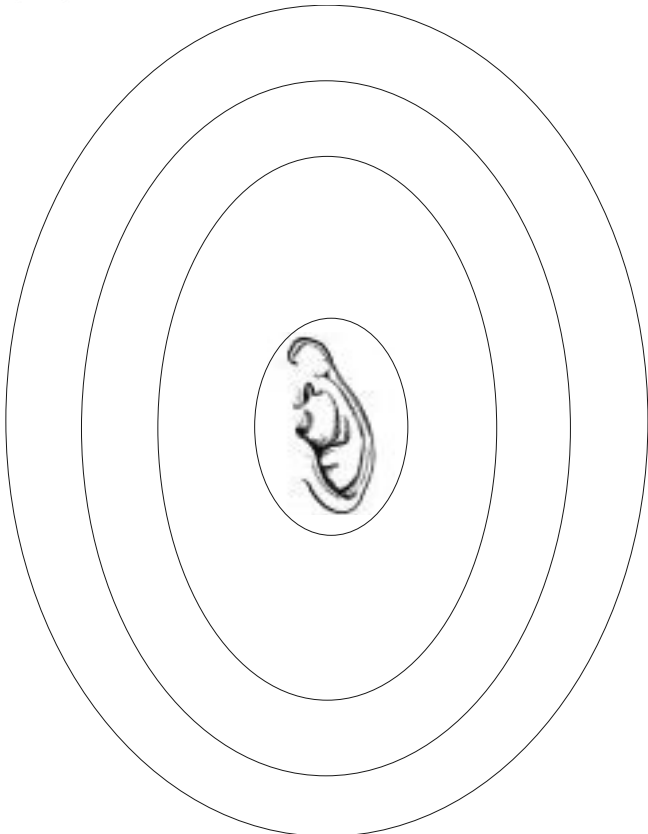

You are at the centre of the map – use the rings to show important parts and sounds of the environment around you

### Sound Map

**Sound Diary**

Date: \_\_\_\_\_

Place: \_\_\_\_\_

**How many sounds can you make with your feet on the ground? Try moving different ways. Try walking in different places. Describe each sound. Describe the ground.**

| Sound | Ground |
|-------|--------|
|       |        |
|       |        |
|       |        |
|       |        |
|       |        |
|       |        |
|       |        |

What sound do you hear?

Where are you?

Where is the sound?

Draw a picture of the sound or where you are:

**Where can you find a sound of nature on the playground?**

### Sound Diary

Date:

Place:

Large empty box for writing or drawing.

Large empty box for writing or drawing.

Place:

Date:

### Sound Diary

Large empty box for writing or drawing.

**Put your ear to a flat surface and listen. What can you hear? Have your partner make a sound somewhere on this same surface and listen again. What does it sound like?**

What sound do you hear?

Where are you?

Where is your partner?

Draw a picture of the sound or where you are:

Large empty box for drawing or writing.

**Where can you find a peaceful sound? Describe where you can hear it - what it is like?**

Large empty box for writing or drawing.

Draw a picture of the sound or where you are:

Where is the sound?

Where are you?

What sound do you hear?

# Sound Diary

Date:

Place:

Large empty box for writing the sound diary entry.

Large empty box for writing the sound diary entry.

Place:

Date:

# Sound Diary

Large empty box for writing the sound diary entry.

**What is your favorite sound outside right now? Why do you like it so much?**

What sound do you hear?

Where are you?

Where is the sound?

Draw a picture or write about why you like the sound

Large empty box for drawing or writing about why you like the sound.

Why do you wish you couldn't hear this sound?

Describe the sound

**What sound do you wish you couldn't hear right now?**

Large empty box for drawing or writing about why you wish you couldn't hear the sound.

Why do you wish to hear this sound?

Describe the sound

**What sound do you wish you could hear right now?**

Large empty box for drawing or writing about why you wish you could hear the sound.

### Sound Diary

Date:

Place:

|  |
|--|
|  |
|--|

|  |
|--|
|  |
|--|

Place:  
Date:  
**Sound Diary**

**Choose a destination point you can see from where you are. During your walk to that point keep a record of all the sounds you hear.**

Describe this point?

What sounds do you hear?

Where are they coming from?

|  |  |
|--|--|
|  |  |
|  |  |
|  |  |
|  |  |
|  |  |
|  |  |
|  |  |

What sound do you hear at the destination point?



Label the parts of your body with the sounds they made

**Describe all the sounds your body made during the scavenger hunt**

### Sound Diary

Date:

Place:

Large empty rectangular box for writing the sound diary entry.

Large empty rectangular box for writing the sound diary entry.

Place:

Date:

### Sound Diary

Small empty rectangular box for writing the date and place.

### Sound Diary

Date:

Place:

Large empty rectangular box for writing the sound diary entry.

Large empty rectangular box for writing the sound diary entry.

Place:

Date:

### Sound Diary

Small empty rectangular box for writing the date and place.