

## Construction

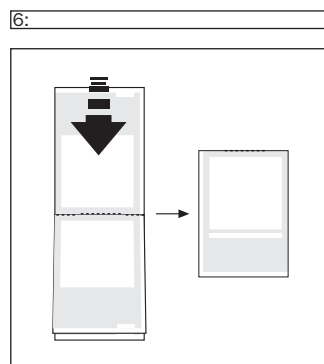

- 1: First, fold each sheet in half along the vertical axis.
- 2: Using a craft knife or scalpel, cut a horizontal slot along the centre dotted line of the first sheet. (pages 1/2/13/14)
- 3: Then cut along the dotted lines on all the other sheets. Make sure to cut to the very edges of the paper.
- 4: Stack the folded sheets in ascending order with the even numbers at the top. Curl the bottom half of the second page (pages 3/4/23/24).
- 5: Thread the curled page through the centre slot of the first page. Repeat this process with the third (pages 5/6/21/22), fourth (pages 7/8/19/20), fifth (pages 9/10/17/18) and sixth sheet (pages 11/12/15/16) with the even pages in ascending order.
- 6: When all the pages have been threaded through, check the pagination. Finally, fold the booklets in half along the horizontal axis.

DIFFUSION eBook format conceived & developed by ProboScis, a non profit organisation which researches, develops and facilitates creative innovation. An alternative to prevailing formats for ebooks and electronic publishing, ProboScis welcomes the free adoption and use of DIFFUSION by any third party without licence or royalty.

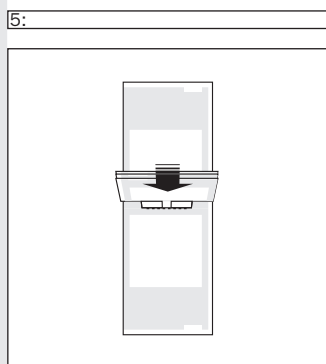
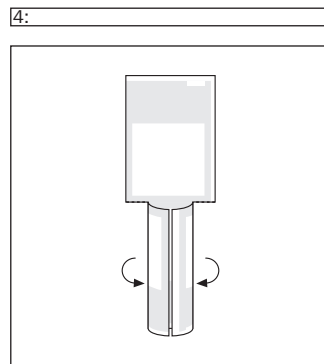
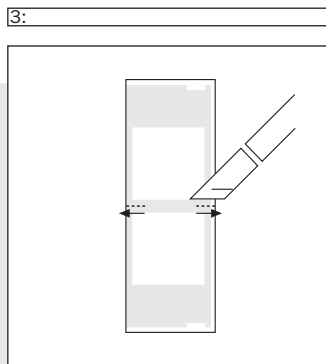
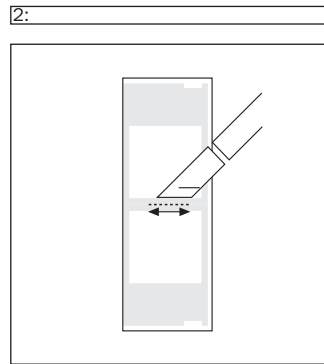
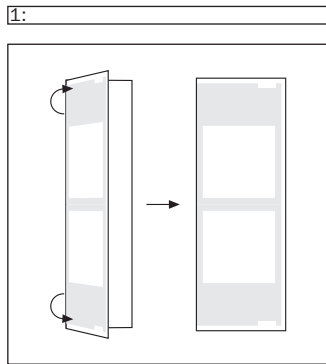

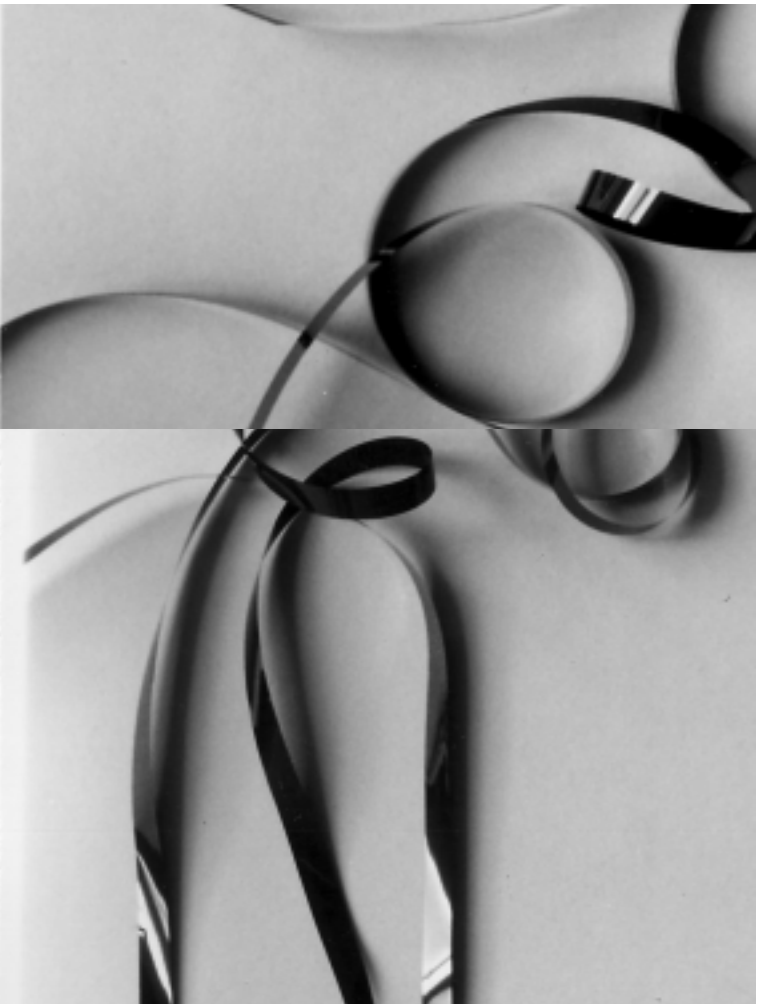

Voiceover

Mohini Chandra

PERFUSION

# DIFFUSION

This publication is one of a series commissioned by Proboscis alongside the Landscape & Identity: Language & Territory Creative Labs held in March and June 2002. Using the themes of Landscape & Identity: Language & Territory, the eBooks explore how innovative use of new technologies can transform our perception of other societies and cultures, territories and places, and provide enabling tools which are a catalyst for the development of new ideas. The LI:IT eBooks and Creative Labs investigate collaborations between the arts, academia and civil society organisations using new media and technology. They are part of SoMa's Liquid Geography research theme.

This publication is designed to be freely available to download and print out. Under no circumstances should any version of this publication, whether print or electronic, be sold by any third party without prior permission in writing from the publisher.

DIFFUSION eBook design by Studio Tonne and Nima Falatouri (NMO Design)

British Library Cataloguing-in-publication data: a catalogue record for this publication is available at the British Library.

ISBN 1 901540 26 X

Free  
All rights reserved  
First published by Proboscis in 2002  
© Proboscis & Mohini Chandra  
Series Editor: Alice Angus  
www.diffusion.org.uk  
Voiceover  
Mohini Chandra  
Landscape & Identity: Language & Territory  
Voiceover



