

## Construction

1:

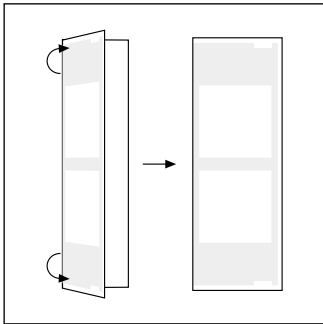

2:

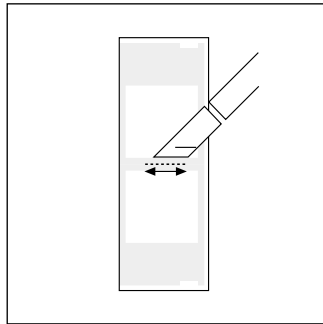

3:

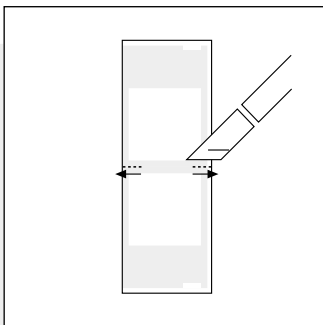

4:

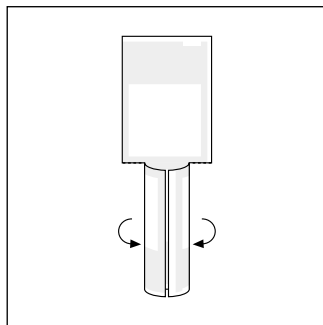

5:

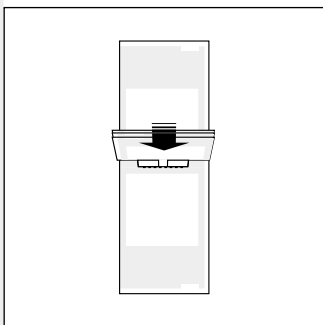

6:

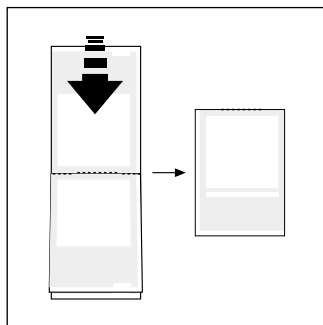

- 1: First, fold each A4 sheet in half along the vertical axis.
- 2: Using a craft knife or scalpel, cut a horizontal slot along the centre dotted line of the first A4 sheet. (pages 1/2/7/8)
- 3: Then cut along the dotted lines on all the other sheets. Make sure to cut to the very edges of the paper.
- 4: Stack the folded sheets in ascending order with the even numbers at the top. Curl the bottom half of the second A4 page (pages 3/4/11/12).
- 5: Thread the curled page through the centre slot of the first A4 page. Repeat this process with the third (pages 5/6/9/10) with the even pages in ascending order.
- 6: When all the pages have been threaded through, check the pagination. Finally, fold the booklets in half along the horizontal axis.

mirrors of the world; they tell us as much about their makers and their clients as of the worlds they claim to represent. Physical maps, it turns out, may not be a good place to start to find out about space and place. What then of the most sneaky and mistrusted maps of all: political maps? Political maps contain traces and residues of social struggles; politics is, in part, about a struggle to sustain sovereign territory. Political maps are about formal social relations fixed through alliance and agreement; this is the evidence that we see on maps. Maps are then used as tools with which to discipline land users and to define transgressors. Political maps – all maps - are about wishes and desires; it's clear that they do not reflect the messiness of real life; we might better see them as a struggle to bring the world in line with the map rather than vice versa.

Perhaps we should not begin with the notion of spaces as grid squares to locate, and to be filled up, or places to draw lines around. We should begin with people and activities and how they make spaces and places through action and interaction. We can hold on to one aspect of the political map version of space in the sense that we all practice our space in different ways, and thus constitute its, and our, spatial identities in different ways. So, our starting point should be an expectation to see spaces, not space. Each space is the result of actions, movements and interactions; our attempts to share and express, as well as to contest place and meaning.

It is not only that space is multiple; nor, that it is practised from within. We must further explore how space is also crossed and transgressed, how it is radically open to an 'outside', or an 'Other' (although, looked from this perspective, the Other is no longer 'alien', rather they are a 'natural' part). Thus, spaces must be about travelling and movement, about leaving and returning, longing and belonging; they are about social networks. Consider the issue of openness; here we have to deal with the subtle interactions of identity, space, time and movement. When we move from one place, A, to another, B, we carry with us a 'version' of A, A1, with us. However, we immediately suffer a loss: A has changed to A2 since we left, A1 is no

It's space Jim, but not as we know it.

Andy C Pratt



A good place to begin might be with the re-examination of the idea of space. At first, nothing seems simpler: describe and represent the world through its physical markers. The problem, familiar to anyone who has tried to draw a map, is that physical markers are socially selected, depending on a choice being made by the maker or definer, they give differential prominence, a preferential reading of the world. Maps are far from innocent

Both the visionaries of cyberspace, as well as its current manifestations, work with an implicit mind set composed of a series of dualisms: mind-body, on-off line; where identity and place have absolute, unitary and stable meanings. Is there another way of thinking and acting through this issue; is this the only scenario? The point of the remainder of this essay is to outline a different mode of thinking about this problem. This is not a practice in idealism, as if simply thinking differently changed things. It is a material act: one based upon material practices; if we would only open our eyes to see them. The starting point is to view space not as absolute, pre-determined, and externally mapped, but instead as relative, social and relational. We need to understand technologies not as 'silver bullets', but as provisional, contextual, socially formed and socially forming. We should also see identities as situationally constructed: made through interaction, whether on, and/or off-line, and malleable, in the sense of being presented in different ways in different times, places and social settings. Hopefully, we can pull away from the stultifying dualisms and determinisms that press down upon us from journalism and the everyday taken for granted'.

**HYBRID, OR LIQUID, SPACES**

puter, you cannot hope to benefit from the internet revolution. The notes and coins, cash-based, material economy is becoming a strange sort of ghetto, one turned inside out. Post office and banks have deserted our deprived urban neighbourhoods; to cash a benefit cheque may require a visit into one of the middle class suburbs, or the city itself; places where a premium is set upon face to face customer support'.

Why should we worry about representations of space in science fiction? Writers such as Gibson have been employed by technology and software companies to advise on product design, to help to shape our material worlds. Moreover, the circulation of cyberpunk and associated ideas has flowed into a wider circle of designers and users of related products. An example of how a good idea can't be kept down? Maybe, but my concern here is to suggest that we are working with an impoverished version of 'space'; other versions of which might create a whole range of other possibilities, as well as avoiding some of the negative aspects of ordinary space'.

In these novels characters use a posthetic interface to 'jack in' to cyberspace. Cyberspace is a no-place, a virtual reality everplace, where there are no limits to possibility and few rules. As a plot device for fiction, Gibson's idea of cyberspace is fantastic, however, it is unwieldy without the usual constraints of rules and limits. Thus, cyberpunk writers have created social worlds, with social norms – not that this is anything unusual, it is a characteristic of all fantasy writing. The most innovative element has been the construction of 'new worlds'; this time the new world is not just another planet, but cyberspace itself.

In these technologically convergent times it is tempting to imagine an end to space and time, instead we could envisage an arrow constantly piercing a hexhaustible horizon, not only inhabiting in an eternal present, but also in a non-space/ever-space. This vision is strongly indexed with technology-cal products and the dreams that we have woven around them: the 'mobile and WAF-enabled' mobile telephones are emblematic, more so than mobile computing, because they are structured around about continuous interaction and in that they are more closely integrated with the body, commonly being worn and/or displayed as a fashion accessory. They knowingly draw upon a materialised version of science fiction: notably that of the cyberpunk genre; particularly that found in William Gibson's *Neuromancer*, and Neal Stephenson's *Snowcrash*.



DIFFUSION

This publication is one of a series commissioned by Proposcis alongside the Landscape & Identity: Language & Territory Creative Labs held in March and June 2002. Using the themes of Landscape & Identity: Language & Territory, the ebooks explore how innovative use of new technologies can transform our perception of other societies and cultures, territories and places, and provide enabling tools which are a catalyst for the development of new ideas. The L-LT ebooks and Creative Labs investigate collaborations between the arts, academia and civil society organisations using new media and technology. They are part of Somia's Liquid Geography research theme.

DIFFUSION ebook design by Studio Tomne and Nima Falatouri (NMO Design)  
 British Library Cataloguing-in-publication data: a catalogue record for this publication is available at the British Library.  
 ISBN 1 901540 30 8

© Proposcis & Dr Andy C Pratt  
 First published by Proposcis in 2002.  
 All rights reserved.

www.diffusion.org.uk  
 Series Editor: Alice Angus

Dr Andy C Pratt  
 It's space Jim, but not as we know it

LIQUID GEOGRAPHY:  
 Landscape & Identity: Language & Territory

### ORDINARY BODIES, ORDINARY SPACES, ORDINARY IDENTITIES

What is ordinary space? 'Space' as a concept is so banal that we seldom think about it. However, a moment's reflection alerts us to the surprising fact that we have constructed a vast array of means to impose meaning on space, and, that it has no intrinsic meaning: it is a blank. So, we use measurements to define space, we adopt physical markers, then we attempt to attach meaning. Thus, within ordinary space, space is merged with measurement: measurement of size, and the determination of location. As is well known, the familiar grid of the map and the lines of latitude and longitude are an artifice. However, they enable us to conceptualise location in a shared framework: so, two people who have never visited a point on the earth can agree on co-ordinates and meet there. The problem is that these technologies of location and mapping have come to represent the world

Integral to ordinary space are a commonly linked set of assumptions about identity that are fixed and unitary in their nature (just like those manifest in the pre-digital world). Unless we are suffering from a 'bi-polar disorder' then we have a single identity that remains more or less fixed through life. Moreover, this identity is linked to, and bounded by, the bodies that we inhabit; consider the disdain linked to those professing 'out of body experiences'. These notions of body and identity commonly spill over into the physical spaces that we inhabit. So, places have boundaries, they can be delimited and described, and they have unitary and relatively stable 'characters'. So strong is this notion that the description may flow from place to bodies, as well as from bodies to place. The place is a sum of the local, regional or national character; and vice versa, that place 'makes' people a particular way. This latter version has a long history that is collectively termed environmental determinism. Modern, urban, versions will be familiar to all ranging from a socio-spatial pathology to normalisation. An example of the former are the 'bad parts of town' that criminals or otherwise socially undesirables, as determined by the speaker, come from; an example of the latter is the notion of the liberating conviviality of the city square. These

Let's now return to the cyberspaces as described by novelists, and, that are assumed in many technologies. What is this space, and why should we be concerned by the representations of it? The initial idea of cyberspace was literally a non-space, the imaginary place where, for example, a telephone conversation exists. Cyberpunk writers melded this 'phone(y) space' with virtual reality and thus opened up the idea that this imaginary space could be occupied by virtual creations. Perhaps the most evocative of which are the digital simulacrum of people that Stephenson famously characterised as 'Avatars'. The new space turns out to be very similar to the old spaces that other writers re-named as far away lands, or worlds; similar in the crucial sense: that whatever weird and wonderful creatures inhabit them, they generally accord to school textbook geometry versions of space. Despite the literally infinite possibilities that could have been imagined for such a new space it is disappointing to discover that, on closer inspection, the new space is very much like the old space. Cyberspace is located in a 'grid', or a 'matrix', and hence constituted as 'absolute spaces' defined, just like the grid reference of a map. This is the world according to the studying digital binary of either/or, not the creative possibility of hybridisation. This is the crux of the matter, these spaces are described and determined, like the interaction that takes place within them, by an implicit set of rules and assumptions.

### CYBER-SPACES: LIBERATION, OR THE SAME OLD DUALISMS?

notions of ordinary space are constituted by ideas of stability and containment and a strong identification of 'inside-outside', 'belonging-not'. It is not surprising that there is juxtaposition to movement outside; those in transit are outside the norm, and labelled as migrants who transcend boundaries. Ideas of ordinary space could be considered as a normalising regime that encourages designers, and users of technologies and places, to adopt conformity, as well as pathologising difference, hybridity and fluidity.

erated more travel congestion and pollution to maintain them. This is a modality that is based upon the assumption of movement and travel. As we noted above; the economic rationality of such a system is the concentration of key resources in a few places.

The problem is for those who cannot travel, and / or access on-line services. They will quickly become lost in the sea of connectivity, interaction and travel; one in which they cannot swim. The issue is not one of 'only connect'. Everyday life is about struggling, usually on foot or by public transport, to maintain connections of basic resources that get harder to obtain and retain. Characteristically, the poorer and more socially disadvantaged have to work far harder at making all sorts of connections, all of the time. It would be a relief not to have to make another connection in order to obtain basic resources. Thus, the challenge is a social-spatial one more than a technical one; however, the technical dependency that we have in large part chosen has shaped this problem.

We need to attend to the relationships between the connected and unconnected worlds, both within our lives, and across those of others. The hard work of building social relations for all entails more than 'jacking in'. We also need to recognise the diversity of trans-localism and trans-local identities. It is of course a deceit to assume that the current 'wired generation' are the first to explore this, or indeed are the best equipped to deal with it. Trans-localism has existed for as long as migration created diasporas; the means of managing, and oftentimes failing to manage, social relations across time and space that have developed in Diaspora communities, as well as the significant practices of social connection and identity, would repay re-examination in this context.

Above all, we need to boldly go and explore the new space and practice, casting aside the assumptions of space that we have misused for so long. Instead, we need to pay attention to both the practices and the conflicted and hybrid nature of space, place and identity making.

At first sight cyberspace is a place of liberation from all of the limitations, the material and immaterial shackles and chains, of everyday life. It would seem that cyberspace is the antithesis of normalisation. First the material constraints, this is the much trumpeted 'death of distance' allegedly afforded the new technology user. Users need no longer shift their material bodies through time and space to meet with others, they can simply 'connect' via digital transfer at the push of a button.

But, there is strangely contradictory evidence of this 'death of distance'. The fact that we are travelling more than ever, in fact as an exemplar of those who are perhaps most likely to be part of the 'wired society', the international business executive, within the next period of the next 15 years it is forecast that total air traffic will double. This may be because of the 'bandwidth deficit' that makes email or even video conferencing a poor substitute for interaction In Real Life (IRL). Technologically, we are a long way from a 100% bandwidth that would require complete virtual co-presence, or teleporting. It could be argued that technologies have progressively reduced the bandwidth deficit: from telex, to telegraph, landline to fax, and video-conferencing to steaming video. However, it seems that not only does face-to-face communication continue to be popular, but it is more popular than ever. Web designers and internet developers, surely the archetypal wired generation, still group together in physical proximity in the open plan lofts within a few blocks of one another in areas of San Francisco, New York and London.

There is an irony in the fact that our obsession with cyberspace has been elevated by the convergence of mobile telephony and the internet. If connection was all then we should never want to leave home: the death of distance hypothesis. It seems that the opposite is closer to the truth: more connectivity means even more going out and meeting: hyper-mobility rather than stasis.

Second, the liberation from immaterial constraints. Here, we have seen a considerable out pouring of debate concerning the ability to create on 'on-

Technological changes have opened up possibilities for many that has led to a trend to move toward services and resources, so we have travelled more, and demanded goods to travel further to us. We have also established more diverse and eccentric social networks. These in turn have gen-

Our networks, that is our traces of movement and connectivity sketch foot-prints on the world such that we may become 'earthling points' for interactivity; drawing in other spaces and places and turning our own inside out. Such an idea has radical implications for making places and making identities. If we accept the description of the new spaces of practice that are opened up through a broader appreciation of space-time, and the hybridisation of the previously assumed binaries of communication and movement, then we are faced with a number of challenges. We have built and managed our world on the basis of absolute spaces, when a relative notion is more accurate. So, driven by the assumed integrity of ordinary spaces we have sought to deliver services and jobs to people, in turn this has encouraged people to move little and interact more strongly in the local areas and thus build strong local identities.

**NEW CHALLENGES FOR NEW SPACES**

longer A, nor A2. We suddenly discover that we can never go 'home' to A3. To cope with this loss we might try to replicate A in B, this is perhaps A3. Meanwhile we may share with others who also left A, a common A1 yearning for what is an imaginary space and imaginary identity: but perhaps real enough to form a political or social movement around. This A1 has been termed 'third space'. This hybrid space is a more complex and, a more interesting and challenging notion of cyberspace than the matrices and grids of science fiction. We might think of folding these notions of third space, that have been used to think about post-colonial identity formation, back into the more banal of the diurnal routine of how we stretch our homes, work and leisure: added to which we also may stretch parts of ourselves across space via a telephone or email conversation whilst still occupying a particular physical space.

The *de soto* third element of the debate about the liberatory potential of new technologies concerns the issue of 'connection' to these new technologies. If one is not connected, or doesn't have the skill or the social capacity to interact in a particularly stylised fashion, then one is excluded from all of this much-vanished potential. This should remind us that technologies have situated value and utility; take them out of a particular setting and they may have no value: they are neither unitary (meaning the same to everyone), or universal (the same everywhere). Moreover, as there is increasing public and private infrastructure investment in promoting online transactions, information and service delivery, there is parallel a substantial dis-investment in off-line resources. Thus, the off-line world is hit with a double exclusion. If you haven't got a bank account, let alone a com-

However, it must be pointed out that we do have a corporate existence, one that is generated, classed, aged and ethnically identified in a particular social and spatial setting. Thus, identity is a corporeal issue, not simply concerning adornment and display, but also ethnicity and the situated nature of identity and interaction: put simply, context matters both to who we are and how we are. Whatever 'new' identities are explored they will always have a relationship to the old. Similarly, some of the early electronic frontier commentators saw on-line communities as a salvation for democracy: it would create a new and safe place to colonise where the troubles of the world could be left aside. However, critics of this form of online, elective community have pointed out that however one defines community, it usually involves commitment and engagement with a situated, 'ground' group in a particular place, not simply an elective. Making social relations, and making identities, is hard work, if you disagree you can't simply log-off, you have to stay around to deal with the consequences.

line' identity. This issue rests on an exploration of the mind-body relationship. Many commentators writing about the possibilities of cyberspace and identity draw upon a crude version of spatial-socio-determinism, arguing that we are prisoners of our bodies and environments; thus, on-line identities can be a liberation, an opportunity to live other existences.