

Construction

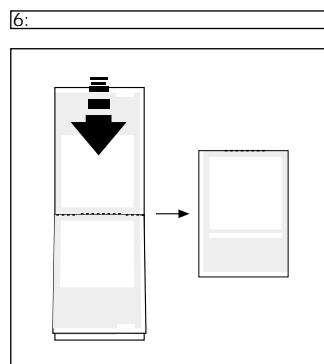

- 1: First, fold each sheet in half along the vertical axis.
- 2: Using a craft knife or scalpel, cut a horizontal slot along the centre dotted line of the first sheet. (pages 1/2/9/10)
- 3: Then cut along the dotted lines on all the other sheets. Make sure to cut to the very edges of the paper.
- 4: Stack the folded sheets in ascending order with the even numbers at the top. Curl the bottom half of the second page (pages 3/4/15/16).
- 5: Thread the curled page through the centre slot of the first page. Repeat this process with the third (pages 5/6/13/14) and fourth sheet (pages 7/8/11/12) with the even pages in ascending order.
- 6: When all the pages have been threaded through, check the pagination. Finally, fold the booklets in half along the horizontal axis.

DIFFUSION eBook format conceived & developed by ProboScis, a non profit organisation which researches, develops and facilitates creative innovation. An alternative to prevailing formats for ebooks and electronic publishing, ProboScis welcomes the free adoption and use of DIFFUSION by any third party without licence or royalty.

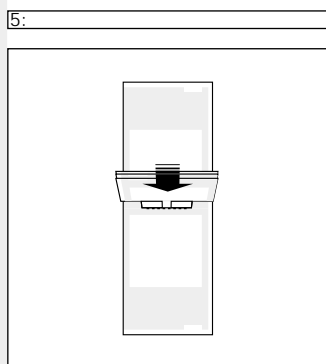
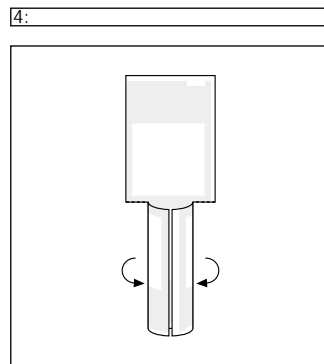
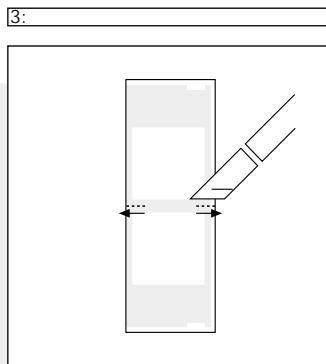
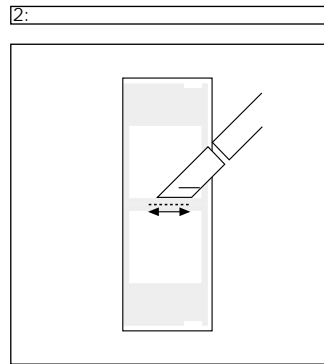
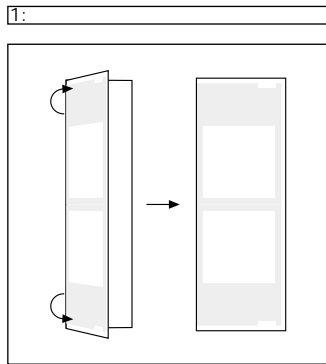

Travelling clichés.

So I filled my time, I went to the art gallery and saw some fabulous heroic scenes. I went to church and visited a mausoleum to a sculptor (a sculptor of smooth alabaster buttocks and breasts). The pyramid of marble that made up it's facade surpassed a nearby memorial for a head of state, it was larger, more beautiful, more monumental. I eat garlicky squid cooked in black sticky ink, swirling about in a wet warm corn mush. I walked down to the boat yard and saw the asymmetrical building of the local craft that are designed to glide with a sideways drift. I made love all afternoon in the hotel bedroom with the companion who was busy, I walked the laundry-hanging back alleys and trod in the dog excrement. I drank too much at dinner with friends and blushed easily. There were no children around. This is a city where people do not often give birth and it is a city where the cemetery is full and there is no space for the dead.

I waited for Sunday.

I decide that I will copy the recording and leave it for you so you can copy the file onto your desktop if you think you might want it later, or ignore it if it isn't what you are interested in. I would know that you would know, it was *there* for you anyway.

THE ISLAND BELL

KATHARINE MEYNELL

DIFFUSION



I shall describe what it was like away from that time. Catching up with myself, I am learning to speak of myself in the third person, mouthing and whispering the words as my fingers touch the keys, hoping to make the words written sound as if I had spoken them to you. I speak them to myself and of myself. I am looking down at my hands tapping, I don't really see the end of my fingers much, my head is bent and as a bad typist I can only occasionally look up to the screen.

I did not write down the events day by day

It was humid that day, every now and then great waves of rotting urban stink accompanied by the buzzing pitch of cicadas. Several buildings of historical significance with old uneven mosaic floors. One still used as a site of pilgrimage where venerated bones are kept in a glass sided box. The bones were masked and dressed as if a person was lying there, fully grown but still the size of a small child.

There was so much to see here in the city, but instead we took a boat to another island, although we did not know what exactly we were going for.

Where we disembarked some heavy machinery was moving piles of earth and concrete. Walking between channels of water on reclaimed land we were accompanied by the buzzing pitch of cicadas. Several buildings of historical significance with old uneven mosaic floors. One still used as a site of pilgrimage where venerated bones are kept in a glass sided box. The bones were masked and dressed as if a person was lying there, fully grown but still the size of a small child.

Kasia Boddy

"The age of tourism, it is frequently noted, is also the age of mechanical reproduction..."



This publication is designed to be freely available to download and print out. Under no circumstances should any version of this publication, whether print or electronic, be sold by any third party without prior permission in writing from the publisher.

ISBN: 1 901540 16 2
British Library Cataloguing-in-publication data: a catalogue record for this publication is available at the British Library

Proboscis gratefully acknowledges the support of the Arts Council of England and the CRD Research at the Royal College of Art in making DIFFUSION possible.

DIFFUSION Print design by:
Noel Douglas

DIFFUSION Interaction design by:
Paul Farrington (www.NMDesign.co.uk)
Nima Falatouri (www.NMDesign.co.uk)

© Proboscis & Katharine Meynell
First published by Proboscis in 2000.
All rights reserved.

KATHARINE MEYNELL

Series Editors: Giles Lane & Catherine Williams
www.diffusion.org.uk

THE ISLAND BELLS
Katharine Meynell

The volume of it
and the void.

You might assume that the protagonist is female, because the coat and gloves, although borrowed, were gendered, and you might approximate my age by other traces I have left. If I get confused I can tell by listening to my voice and noticing my finger joints.

Where is the
resemblance
between what was
written and who
wrote it.

and slept quietly for an hour. This not-journal, tabulating unfinished autobio-graphical events, is almost complete at this stage. I have whispered them back to my self, head bent over the keys. As I speak I wonder if I have made my foolishness sound more interesting. Probably – it justified leaving a trace where none was needed.

I do not know why
I have a tape
recorder at this
time, there is no
reason that I can
recall for it being
in my possession.

We walk up the tower – it is dark, cooler, slightly damp, the stairs spiral around quite steeply, there are occasional windows out over-looking the salt wetlands. Up, up, up, catch your breath, my breath. The bell at the top of this tower starts to ring, it is an enormous sound, I fumble and get out a tape recorder, placing the microphone slightly behind me to get the footsteps of the person behind. We come out at the top, it is open on four sides, the bell is very large, it is suspended so that we can look into the belly of it as it swings back. The landscape behind and in front goes out beyond the islands, we can see for miles. It is slightly misty. The sound is colossal, my chest reverberates, *I am scared.*

There was a door
at the bottom, we
walked in.

Behind this building, standing alone with a separate entrance, was a tall red brick tower.



In my sleep I can't find the map but I know it takes 8 minutes to reach the earth from the sun.

We got up early and walked quickly to the quay on the north side of the island, where we caught a number 12 ferry. It was very bright, very cold. I had my daughter's coat with a fake fur collar wrapped tightly around me, my grandmother's gloves on with a button missing from the cuff. We took photographs and we let the video run most of the way. Where we disembarked the heavy machinery was motionless, walking between channels of water on reclaimed land it was silent except for the taking off and landing of planes in the distance. The buildings seemed closer than before. We went round the back to the tall red brick tower. The gate to it was shut, but we slipped through beside a wooden post and went up to the bell tower door. It was locked. We walked back around to the building at the front and with my limited vocabulary I asked if we could have access to the bell ringing. They understood my faltering words and carefully explained that it was closed from November to April. We waited outside on the grass for a long while. I listlessly let the DAT run over the mid day hour in case the bell rang anyway. Nothing happened so we returned to the ferry. My companion expected me to be upset, but I was relieved. I recorded the ferry engine as we crossed back to the city-island where we were staying. I went back up to the hotel room and had a hot shower



Back in a hotel room, cool with air conditioning, I realise the tape recorder was on 'pause', I have not captured my moment of terror. There is an indeterminacy to a sound being heard. I try to be vague, but some definition has occurred, edges have materialised with telling, remembering or imagining. Areas perceptually indistinct are discarded for lack of description. If I had done the recording, (audio limiter on) it could be precisely repeating (something I hadn't heard) somewhere else. Knowing how flawed this recording would have been and how incapable of creating the sound, as I had heard it, I should have been content to recount this to my keyboard, whispering at my fingers. But I was not. A second journey was made just before spring. I know this is ridiculous, I had made the first journey because I was near by and because I did not know what was there, how could I possibly go to the same place to do that again?





The impulse to go was underscored by a nostalgia, not a longing for the past but a yearning to catch the urgency of the present. It is a confusing state, emotionally adolescent like mooching around to pop songs waiting for something to *happen now*.

You could turn it up loud.

By then it was winter, I travelled for a whole day by bus and by plane, sweeping down over the snow covered mountains as we came in to land, arriving at the city-island nearby, where (as before) I could get a boat to the island with the bell. I joined a different companion, one who was busy.

We had not made the journey together.

Because the last time I had been to the island it was by chance, this time I wanted to plan things so I could leave with a complete record. I had a video camera, a DAT recorder, a still camera, a note book and pencil. I made enquiries at the hotel lobby about how I could find out when the bell would ring, I was reassuringly told, always on Sunday at eleven in the morning and at mid-day, because all bells ring then. I checked the ferry timetable and planned the quickest route. It was Friday.

